

MULTIPLE PROBE HEPATIC RADIO-FREQUENCY ABLATION: EX-VIVO EXPERIMENTS IN THE PORCINE MODEL

D. Haemmerich¹, F.T. Lee Jr.², A.W. Wright³, D.M. Mahvi³, J.G. Webster¹

¹Department of Biomedical Engineering, University of Wisconsin, Madison

²Department of Radiology, University of Wisconsin, Madison

³Department of Surgery, University of Wisconsin, Madison

Abstract— Radio-frequency (RF) ablation is an important means of treatment of non-resectable primary and metastatic liver tumors. The RF ablation of any but the smallest tumor requires the use of multiple overlapping treatment zones. Commercially available RF ablation generators, unlike cryoablation (a method of tumor destruction that utilizes cold rather than heat), are only capable of driving a single RF probe at a time. Using multiple probes simultaneously in RF ablation is desirable for treating large tumors and for treating multiple tumor metastases. Bipolar RF ablation, which has been previously studied by other groups, allows simultaneous usage of two probes. The energy converted to heat at each probe for bipolar RF ablation is necessarily equal. There have been no investigations of other methods that allow usage of multiple RF probes simultaneously. We investigate feasibility of a new method, where power is applied in an alternating fashion between two or more probes. This method allows independent control of the amount of energy deposited at each probe. We performed *ex-vivo* experiments with one (i.e. conventional ablation) and with two probes. In the two-probe experiment, both probes reached target temperature and created lesions of sizes comparable to conventional RF ablation.

Keywords – Radio frequency, hepatic ablation, bipolar ablation

I. INTRODUCTION

Radio-frequency (RF) ablation is increasingly utilized as a minimally invasive treatment for primary and metastatic liver tumors. Hepatocellular carcinoma is one of the most common malignancies, worldwide with an estimated annual mortality of 1,000,000 [1]. Surgical resection offers the best chance of long-term survival, but is rarely possible. In many patients with cirrhosis or multiple tumors hepatic reserve is inadequate to tolerate resection and alternative means of treatment that target the tumor, but preserve uninvolved liver are necessary [2]. Cryoablation and RF ablation are the most commonly used therapies for cases where surgical resection is not possible. In cryoablation, cold is used to destroy tissue. Cryoablation, unlike RF ablation, allows simultaneous application of multiple probes. Simultaneous application of multiple probes is desirable for treatment of large tumors, and for coincident treatment of metastases.

In RF ablation, RF current is delivered to the tissue via electrodes inserted percutaneously or during surgery. Different modes of controlling the electromagnetic power delivered to tissue can be utilized. Power-controlled mode ($P = \text{constant}$), temperature-controlled mode ($T = \text{constant}$) and impedance-controlled mode ($Z < \text{constant}$) are used. The most commonly used mode is temperature-controlled ablation. Tumor cell death results from the conversion of electromagnetic energy to heat by ionic agitation. Temperatures above 45 °C to 50 °C cause denaturation of

intracellular proteins and destruction of membranes of tumor cells, eventually resulting in cell necrosis [3]. One of the major limitations of this technique is the inability to use multiple probes simultaneously. When tumors greater than 2 cm are treated, multiple applications are necessary to obtain complete tumor necrosis. Often tumor cells survive, which leads to high recurrence rates [5]. In cases where multiple tumors are present, these must be treated sequentially. Treatment time could be drastically reduced, if multiple RF probes could be employed simultaneously.

Several methods have been investigated for increasing lesion size and improving efficacy. Internally cooled probes have been used [7]. Interstitial saline infusion creates larger lesions by cooling and increasing effective electrode area [10]. The cooling effects of large blood vessels and vascular perfusion can be minimized by clamping the hepatic artery and portal vein and occluding vascular inflow [12]. Inflow occlusion however requires a major surgical procedure, which negates one of the major advantages of RF ablation—use in a minimally invasive procedure (percutaneous or laparoscopic). Bipolar RF ablation has been shown to create larger lesions using two needle electrodes, compared to conventional ablation using a single needle electrode, when the two probes are placed close to each other [2]. There have been no investigations of methods other than bipolar ablation that allow usage of multiple RF probes simultaneously.

We investigated the potential of a novel method where power is applied alternating between two probes. The temperatures of both probes' prongs are transferred to a computer. The computer controls the period for which power is applied to each probe via an electronic switch, so that both probes are kept at the same temperature. The method can also be extended to more probes.

II. METHODOLOGY

The system for RF ablation using two probes (probe A and probe B) simultaneously is outlined in Fig. 1. The tip temperatures of both probes ($T_{A,i}$, $T_{B,i}$) are reported to the RF generator, which relays the values to a PC. The PC is running a software implemented PI controller, which controls an electronic switch via a D/A-converter (Module DI-220, DataQ Instruments, Akron, OH) connected to the PC's parallel port. The power P is relayed to probes A and B via the electronic switch, so that the average tip temperature of the two probes is kept equal. The signal $C_{A/B}$ determines, which probe the power is relayed to. At a certain time during ablation, current flows either from probe A or from probe B towards the ground pad.

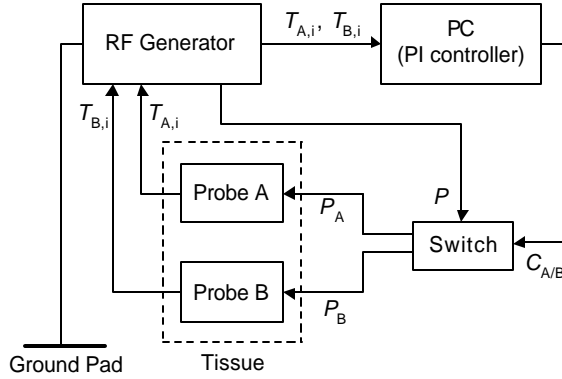

Fig. 1. Block diagram of multiple probe RF ablation system.

For all ex-vivo experiments we used the Rita 1500 RF generator and Rita model-90 multi-prong probes (Rita Medical Systems, Mountain View, CA). The prongs of this probe can be extended to 5 cm. We only extended the prongs to 3 cm to ensure that both probes reach target temperature, since the power is shared between two probes. Each model-90 probe has 5 thermocouples placed at the prong tips, which report the tip temperatures to the RF generator. The RF generator allows for monitoring of 9 temperatures. We monitored all 5 tip temperatures of probe A ($T_{A,i}$), and 4 tip temperatures of probe B ($T_{B,i}$). As a specimen we used liver tissue that we acquired from a local butcher.

We performed ex-vivo experiment #1, where we ablated the tissue with a single probe, at 90 °C temperature-controlled mode for 12 min. The tissue was immersed in physiological saline solution. The saline and tissue were both at 20 °C at the beginning of the experiment. We used software provided by Rita to record temperature and applied power during ablation.

We used the results of experiment #1 to analyze the dynamic system to be controlled and to create an approximation of this system. We then created a computer simulation of the closed-loop system. The dynamic system consisted of the ablation probe, tissue, and dispersive electrode. Since we wanted to drive two probes with the RF generator, we needed to include two dynamic systems (A and B) in the computer simulation. The input variable of the dynamic systems was the power applied, the output variable was the average temperature of the probe prongs.

We used the recorded temperature and power data of experiment #1 to approximate the transfer function of the dynamic system A by a 9th order linear discrete state space model, as given by

$$\begin{aligned} x(n+1) &= A \cdot x(n) + B \cdot u(n) \\ y(n) &= C \cdot x(n) + D \cdot u(n) \end{aligned} \quad (1)$$

where u is the input, x is the state and y is the output.

We used MATLAB (Mathworks, Natick, MA) to determine the approximated state space model of the dynamic system A (i.e. we determined matrices A , B , C and D). Using the same method we created a second state space model for the dynamic system B. The input data (i.e. powers) were not changed, but the output data (i.e. temperatures) were scaled to 80% of the data used for the first model. The model of dynamic system B approximated a situation where higher blood perfusion is present near probe B compared to probe A (i.e. higher power is required to reach the same temperature). We then created a closed-loop system in MATLAB/Simulink including the two state space models (A and B) and a PI controller that controls the power delivered to each of the probes. The closed-loop system is shown in Fig. 2. Under the assumption that the switching of power between the two probes occurs faster than the time constant for change of

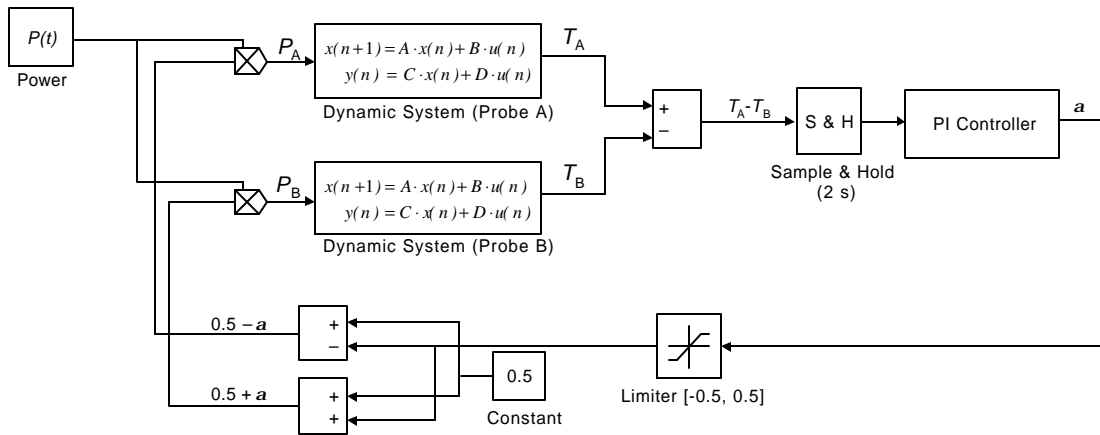

Fig. 2. Block diagram of closed-loop system as used in computer simulation.

probe tip temperatures (i.e. we neglect the ripple in tip temperatures), we introduced a control variable \mathbf{a} ($-0.5 < \mathbf{a} < 0.5$). The limiter in Fig. 2 ensures that variable \mathbf{a} stays within its limits. This variable \mathbf{a} determined the distribution of total power P between probes A and B. The power $((0.5 + \mathbf{a}) \cdot P)$ was delivered to probe A, power $((0.5 - \mathbf{a}) \cdot P)$ was delivered to probe B. The input of the controller was the temperature difference of the average prong tip temperatures of probes A and B. The time course of power P used in the control system simulation was taken from the data acquired for the ex-vivo experiment #1 described above. The time discrete formulation of a PI controller is given by

$$u_n = K_p \cdot e_n + K_i \cdot \sum_{m=1}^n \frac{e_m + e_{m-1}}{2} \cdot \Delta t \quad (2)$$

where Δt is the sampling time, K_p and K_i are the control parameters. Using the computer simulation we determined the control parameters by means of the Ziegler–Nichols method.

We implemented this PI controller in software using Visual Basic (Microsoft, Redmond, WA) on a PC. We used software provided by Rita to obtain temperature and applied power during ablation. The PI controller software acquired the temperature data of the two probes every 2 s from the Rita software (i.e. sampling time $\Delta t = 2$ s). Due to limitations in the Rita software, temperature could not be acquired at smaller time intervals. The sampling time Δt corresponds to the sample & hold element in Fig 2. The PI controller software controlled an electronic switch via a D/A-converter. Depending on the variable \mathbf{a} , Power was delivered to probe A for $((0.5 + \mathbf{a}) \cdot T)$ seconds, and to probe B for $((0.5 - \mathbf{a}) \cdot T)$ seconds. We chose T to be 1 s, so that the ripple in temperature of the probe tips was negligible.

We designed the following ex-vivo experiment #2 to determine performance of the PI controller. We used two pieces of liver, where the initial temperatures of the two pieces were different. One piece was at 17 °C initial temperature, whereas the 2nd piece was at 27 °C initial temperature. Both pieces of tissue were immersed in 27 °C physiological saline solution at the beginning of the experiment. We performed RF ablation for 12 min, at a target temperature of 90 °C. The RF generator controlled the applied power to keep average tip temperature of probe A at target temperature. The PI controller controlled the switch, i.e. it governed how power is distributed between the two probes in order to keep both probes at same average tip temperature.

III. RESULTS

The obtained lesion dimension from experiment #1 where RF ablation was performed the conventional way (i.e. single probe), was 2.3 cm. Fig. 3 shows the time course of variable \mathbf{a} (a), and of the difference in average tip temperature of the two probes (b) for experiment #2, for the first 150 s of the experiment. Fig. 4 shows the time course of average tip

temperatures of probes A and B. Target temperature of 90 °C was reached for both probes after 350 s. The average tip temperature of the two probes was kept within the range of 89.2 °C - 92 °C during the 12 min ablation procedure. The obtained lesion dimensions were 2.3 cm for tissue sample A (initial temperature 17 °C) and 2.5 cm for tissue sample B (initial temperature 27 °C).

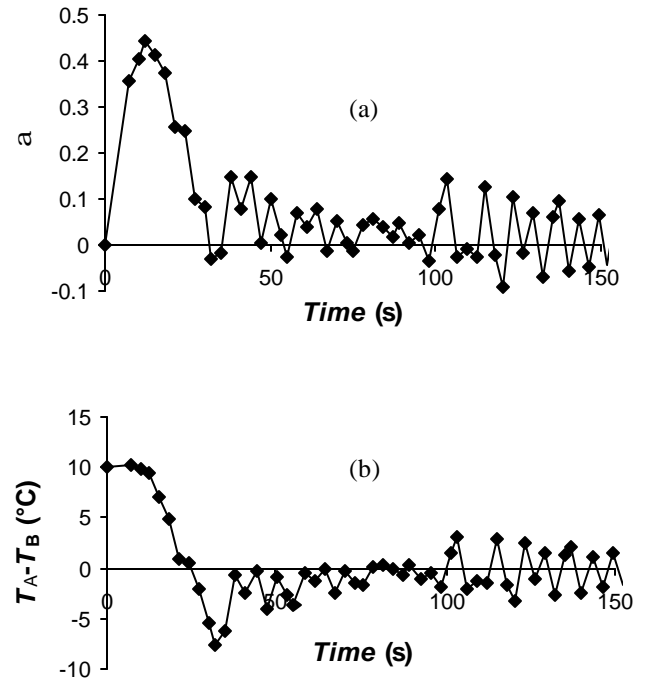

Fig. 3. Results of ex-vivo experiment #2, 12 min ablation with two probes. The time course of (a) control variable \mathbf{a} , and (b) difference in average tip temperature between probes A and B, is shown for first 150 s of the experiment.

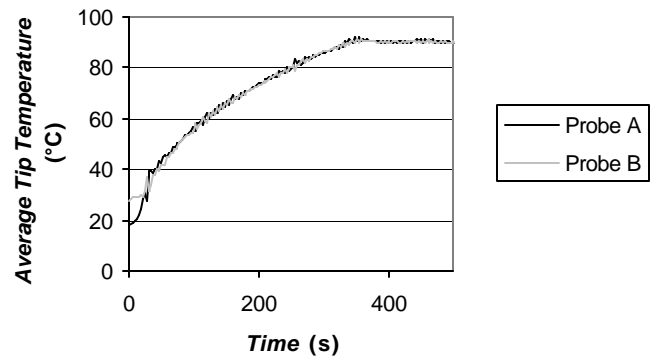

Fig. 4. Time course of average tip temperatures.

IV. DISCUSSION

We evaluated a novel method that allows usage of multiple RF probes. The scheme has been examined by means of an ex-vivo experiment using two probes. The method can be extended to more probes if necessary. Other investigators examined feasibility of bipolar RF ablation, where current is passed between two probes. Bipolar ablation is limited to two probes and cannot be extended to a greater number of probes. Another disadvantage of bipolar ablation is that it does not allow independent control of amount of energy deposited at each probe. All current originating at one probe must enter the other probe. If we assume that similar resistivity and current density are present in the vicinity of both probes, a comparable amount of energy is converted into heat next to each of the two probes. The liver is a very heterogeneous organ, with varying conditions in terms of blood perfusion. If one probe experiences more cooling due to higher blood perfusion than the other, at that probe more heat energy is carried away. In bipolar RF ablation, one probe then reaches a lower temperature than the other.

With the method presented in this paper, the applied power can be independently distributed between both probes. In experiment #2, the two tissue samples (tissues A and B) had 10 °C of difference in initial temperature. Tissue A had 17 °C initial temperature, tissue B had 27 °C initial temperature. Within 40 s, the average probe tip temperatures were equalized by applying more power to the probe that was inserted into the cooler tissue. The parameter α determines how the power is distributed between the probes. Initially during experiment #2, α increased almost up to its maximum of 0.5 (i.e. all power is applied to probe B), and returned to zero as the average tip temperatures of the two probes were equilibrated. Fig. 4 shows the temperature time course of both probes A and B during the first 500 s of ablation. Both probes reached the target temperature of 90 °C after 320 s, and were kept within 89.2 °C – 92 °C during the subsequent ablation procedure. The PI controller performed as expected in the ex-vivo experiment. For experiment #1, target temperature was reached faster than for experiment #2, after only 170 s. This shorter time stems from the fact that for experiment #2, the power was at maximum (i.e. 150 W) for the first 120 s, i.e. the power rating of the generator was not sufficient. The two resulting lesion dimensions of experiment #2 were similar, where the initially cooler sample had a slightly smaller lesion. The tissue sample A with lower initial temperature had a lesion of 2.3 cm diameter, tissue sample B had a lesion of 2.5 cm diameter. Both lesions were similar in dimension to the lesion created in experiment #1 (conventional RF ablation using a single probe), which had

2.3 cm diameter. In our experiment, the power was switched in ~0.5 s intervals between the probes. It has to be considered that by switching the RF generator output, a low-frequency component is introduced into the RF signal. This low-frequency component could excite nerves and tissue (e.g. cardiac tissue). For clinical application it is therefore desirable to switch at frequencies where no excitation is possible, i.e. above 20 kHz.

V. CONCLUSION

The method presented is superior to bipolar RF ablation and conventional RF ablation. It allows simultaneous application of two or more probes. Power can be distributed between the probes to allow temperature-controlled ablation of all probes. The scheme can be used to increase lesion size for ablation of large tumors, or to treat multiple tumor metastases simultaneously. The treatment time can thereby be greatly reduced compared to conventional RF ablation, where ablation has to be performed sequentially.

REFERENCES

- [1] M. C. Kew, "The development of hepatocellular carcinoma in humans," *Cancer Surv.*, vol. 5, pp. 719-739, 1985.
- [2] S. A. Curley, B. S. Davidson, R. Y. Fleming, F. Izzo, L. C. Stephens, P. Tinkey, and D. Cromeens, "Laparoscopically guided bipolar radiofrequency ablation of areas of porcine liver", *Surg. Endosc.*, pp. 729-733, 1997.
- [3] W. Lounsbury, V. Goldschmidt, and C. Linke, "The early histologic changes following electrocoagulation," *Gastrointest. Endosc.*, vol. 41, pp. 68-70, 1995.
- [4] L. R. Jiao, P. D. Hansen, R. Havlik, R. R. Mitry, M. Pignatelli, and N. Habib, "Clinical short-term results of radiofrequency ablation in primary and secondary liver tumors," *Am. J. Surgery*, vol. 177, pp. 303-306, 1999.
- [5] S. N. Goldberg, G. S. Gazelle, L. Sobiati, W. J. Rittman, and P. R. Mueller, "Radio-frequency tissue ablation: increased lesion diameter with a perfusion electrode," *Acad. Radiol.*, vol. 3, pp. 636-644, 1996.
- [6] Y. Miao, Y. Ni, S. Mulier, K. Wang, M. F. Hoes, P. Mulier, F. Penninckx, J. Yu, I. De Scheerder, A. L. Baert, and G. Marchal, "Ex vivo experiment on radiofrequency liver ablation with saline infusion through a screw-tip cannulated electrode," *J. Surg. Res.*, vol. 71, pp. 18-26, 1997.
- [7] E. Delva, Y. Camus, and B. Nordlinger, "Vascular occlusions for liver resections," *Ann. Surg.*, vol. 209, pp. 297-304, 1989.